

Following information is only for EU-member states:

The use of this symbol indicates that this product may not be treated as household waste. By ensuring this product is disposed of correctly, you will help prevent potential negative consequences for the environment and human health, which could otherwise be caused by inappropriate waste handling of this product. For more detailed information about recycling of this product, please contact your local council, your household waste disposal service or the shop where you purchased the product.



T A N S U N Q U A R T Z H E A T

Reference Manual

Rio Grande

UK & EUROPEAN MODEL HEATERS:

**RIO 310 UK & RIO 310 EU,
RIO 315 UK & RIO 315 EU,
RIO 320 UK & RIO 320 EU.**

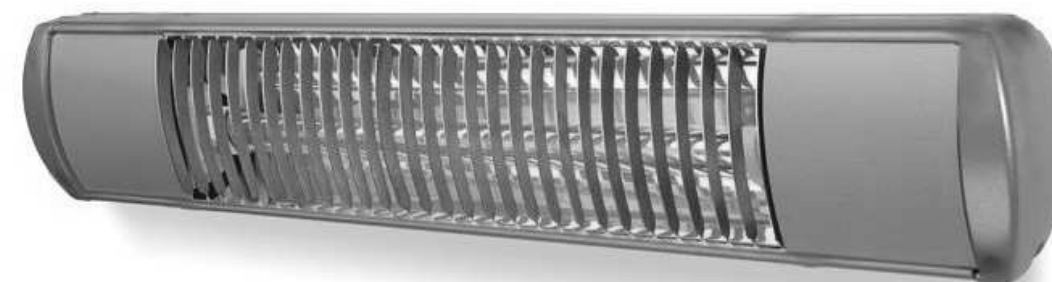

UK & EUROPEAN MODEL HEATERS WITH LIGHTS:

**RIO 310LL UK & RIO 310LL EU,
RIO 315LL UK & RIO 315LL EU,
RIO 320LL UK & RIO 320LL EU.**

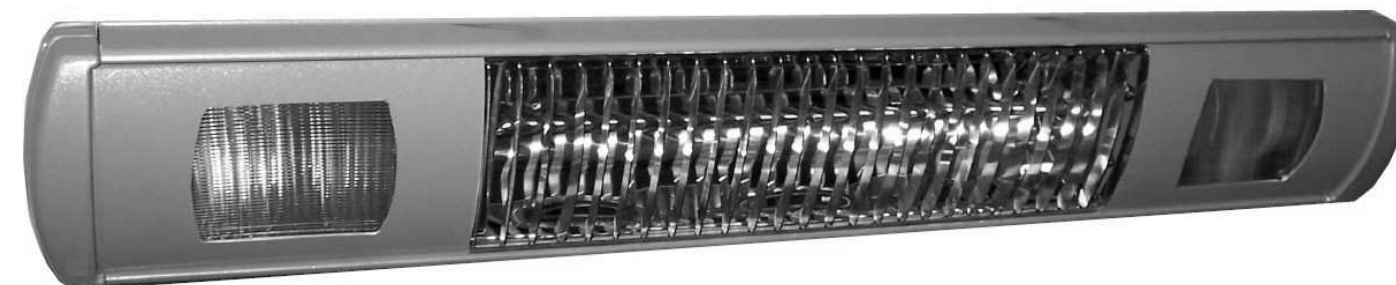

T A N S U N L I M I T E D

Spectrum House, Unit 1, Ridgacre Road, West Bromwich,
West Midlands, B71 1BW, England.

Tel: +44 (0)121 580 6200 - Fax: +44 (0)121 580 6222

Email: quartzinfo@tansun.com - Website: www.tansun.com

Introduction

The Rio Grande heater produces radiant heat like the sun, warming people and objects rather than the air in between. It is mounted on an adjustable bracket that allows the heat to be directed exactly where it is required. Its attractive, lightweight design means that it is effective yet unobtrusive. The Rio Grande is designed for indoor and outdoor use so is therefore weather-proof.

Please read the following instructions carefully before use. The safety of this heater is guaranteed only by its correct usage in accordance with these instructions, therefore it is recommended that they are retained for future reference.

Caution

Before using this appliance:

- Check that the voltage indicated on the type plate corresponds to the mains supply voltage.
- Do not locate the heater immediately below a socket outlet.
- Ensure that the heater has been securely fastened in its final mounting position.
- Remove the plug from the mains socket (or disconnect pole switch) during installation, cleaning and/or replacing the emitter and always ensure that the emitter is cool.
- Do not handle the halogen emitter with bare hands. If it is inadvertently touched, remove finger marks with a soft cloth and methylated spirit or alcohol. Otherwise, the marks will burn into the quartz emitter causing premature heater failure.
- Do not use an extension cable with this product.
- Keep the mains cable away from the body of the heater which will get hot during use.
- Do not cover or obstruct the heater while it is in use.
- The heater is not intended for use by young children or infirm persons unless they have been adequately supervised by a responsible person to ensure that they can use the heater safely.
- Do not insert any object through any slot or opening in the heater.
- Do not use if guard is not present.
- Do not install less than the minimum mounting distance from the floor.
- **Warning - this appliance must be earthed!**

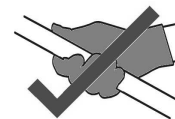

Risk of Fire

Keep combustible materials such as furniture, papers, clothes and curtains at least 1.8m (6 feet) from the front of the heater and away from the sides and rear. If the lamp is to be used outside, we recommend that a waterproof or indoor socket is used.

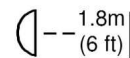

Specification

Table 1. UK and European Heaters

Model	Voltage (V)	Total Power (W)	Current (A)	Min. height from floor (m)	Min. dist. from ceiling (m)	Min. dist. from side wall (m)	Dimensions WxHxD (mm)	Weight (kg)	Ingress Protection (IP)
Rio 310	230	1000	4.3	2.0	0.3	1.0	560 x 112 x 160	2.8	IP24
Rio 315	230	1500	6.5	2.0	0.3	1.0	560 x 112 x 160	2.8	IP24
Rio 320	230	2000	8.7	2.0	0.3	1.0	560 x 112 x 160	2.8	IP24

Use MCB Type 3.

Table 2. UK and European Heaters with Lights

Model	Voltage (V)	Heater Power (W)	Heater Current (A)	Lighting Power (W)	Lighting Current (A)	Min. height from floor (m)	Min. dist. from ceiling (m)	Min. dist. from side wall (m)	Dimensions W x H x D (mm)	Weight (kg)	Ingress Protection
Rio 310	230	1000	4.3	2 x 40	0.35	2.0	0.3	1.0	660 x 112 x 160	3.8	IP24
Rio 315	230	1500	6.5	2 x 40	0.35	2.0	0.3	1.0	660 x 112 x 160	3.8	IP24
Rio 320	230	2000	8.7	2 x 40	0.35	2.0	0.3	1.0	660 x 112 x 160	3.8	IP24

Use MCB Type 3.

BLANK PAGE

3. Unscrew the four screws (see Fig. 1) from the end cap and remove from the heater body. Repeat at opposite end if replacing both light bulbs.

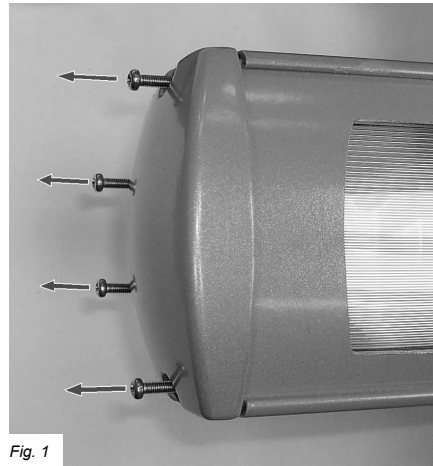

Fig. 1

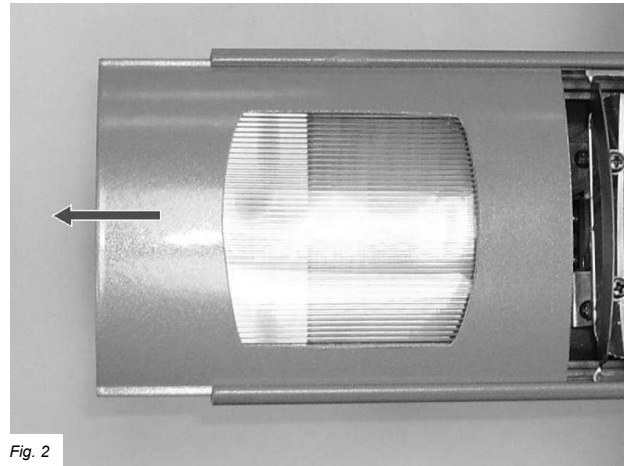

Fig. 2

4. Slide out the side cover(s) to reveal the bulb(s) as shown in Fig. 2.

5. Remove the light bulb by rotating it anti-clockwise until it is released from the bulb holder (Fig. 3).



Fig. 3

6. Refit the new bulb(s) in reverse order ensuring they are not loose and all screws are fully tightened.

Installation

The Rio Grande heater is fitted with 5 meters of supply cable and a moulded plug, therefore it is unnecessary to open the terminal box in order to carry out normal installation of this product and should not be interfered with.

- We recommend using a RCD where applicable.
- Please observe the minimum safe distance between the heater body and any inflammable surfaces.
- If the supply cord becomes damaged, it must be replaced by the manufacturer, its service agent or a similar qualified person in order to avoid a hazard.
- When the electrical connection is outside, it is recommended that a waterproof socket is used for the connection. Otherwise, the plug should be connected to a socket indoors.
- If in any doubt, please contact a suitably qualified electrician.

Mounting

- The Rio Grande heater can be mounted in a horizontal or vertical manner as the emitter is a universal burning type. The Rio Grande heater with lights should only be mounted horizontally.
- When mounting the Rio Grande heater and heater with lights in a horizontal manner, do not position the heater at an angle more than 90° and less than 30° as shown in Fig. A.
- When vertically mounting the Rio Grande heater, ensure to leave a gap between the heater and mounting surface (See Fig. C - dim A). The heater should always be angled downwards when mounting this way with the terminal box at the bottom of the heater - see Fig. 4. Do not position the heater at an angle more than 45° and less than 30° to the horizontal as shown.
- Always allow the heater to cool before attempting to reposition/move. Never attempt to move the heater while it is switched on!
- Observe the minimum safe distance between the heater body and inflammable surfaces and objects when mounting.
- Please refer to Table 1 or 2 for the recommended positioning of the heater.
- Keep out of the reach of children.

1. Securely fasten the Rio Grande bracket to the mounting surface using the fixing holes in the bracket. Please refer to Table 1 or 2 for recommended positioning of the heater.
2. Fix in the required angular position by tightening the fixing bolt on the bracket at the rear of the heater.
3. Secure the supply cable local to the Rio Grande using a 'P' clip (supplied) so the cable is directed away from the heater and is not resting on the body or obstructing the air-vents.

Always isolate the heater from the mains supply when adjusting the angular position.

Maintenance

In the event of heater failure, or for spare parts or advice, please contact the manufacturer in the first instance.

- Disconnect from the mains before commencing any maintenance procedure including cleaning.
- To ensure optimum heat effectiveness, it is recommended that the guard and emitter are removed and the reflector is wiped with a lint-free cloth before reassembling should the reflector show considerable signs of dust or dirt.

Your Replacement Emitter

It is very important that your replacement emitter is exactly the same as the one it was supplied with. Failure to fit the exact same type could cause the heater to fail or even become dangerous especially when used in an outdoor environment. Please contact Tansun Limited to purchase your replacement lamp and state the model number of the heater you wish to fit the lamp to.

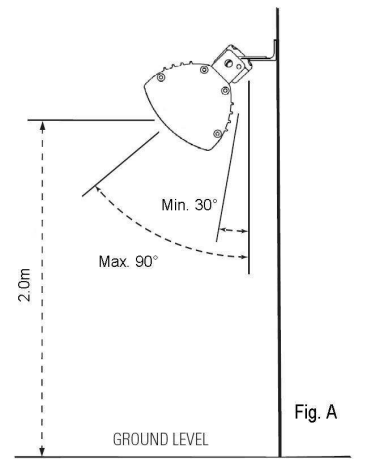

Fig. A

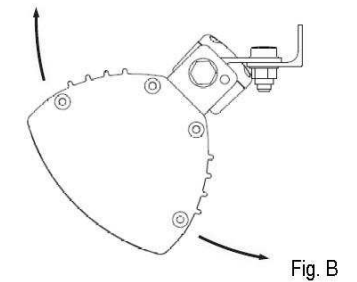

Fig. B

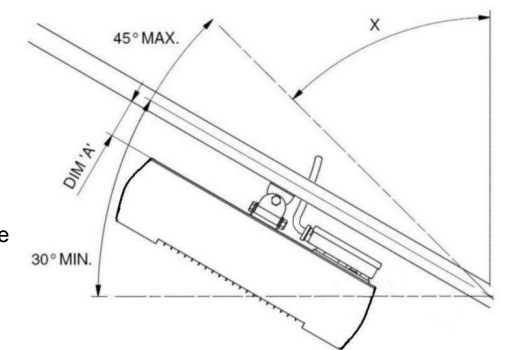

Fig. C

Handling the Replacement Emitter

Your new emitter should not be handled with bare hands. Remove finger marks with a soft cloth and methylated spirits or alcohol. Finger marks will burn into quartz causing premature lamp failure.

Your Replacement Light Bulbs (Heater with Lights Only)

It is very important that your replacement light bulbs are exactly the same as the ones it was supplied with. These bulbs have been designed to withstand high temperatures so failure to fit the exact same type could cause the unit to fail or even become dangerous. Please contact Tansun Limited to purchase your replacement light bulbs and state the model number of the heater you wish to fit the light bulbs to.

Replacing the Emitter

If you are in any doubt about following the procedure below, please contact us for technical assistance. The mains power should be disconnected before any attempts are made to replace the lamp. The following should be carried out with compliance to latest IEE regulations. Please read the notes on the previous page with regards to handling and buying a replacement emitter before proceeding.

1. Ensure the heater, emitter and on models with lights the bulbs are cool and the power supply is disconnected by removing the plug(s) from the socket outlet.
2. Providing there is reasonable access and you are standing on a safe and stable platform, the emitter can be replaced with the heater still mounted. Otherwise, remove the heater from its mounting and work on a safe, flat surface.
3. Remove the screws from the terminal box (Fig. 1) and lift off the cover.



Fig. 1

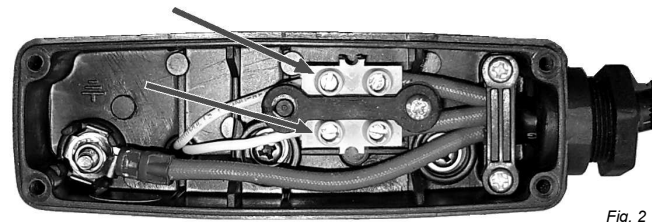

Fig. 2

4. Disconnect the lamp from the connector blocks by unscrewing the screws highlighted above in Fig. 2.
5. Unscrew the four screws (see Fig. 3) from the end cap and remove from the heater body. Repeat at opposite end.

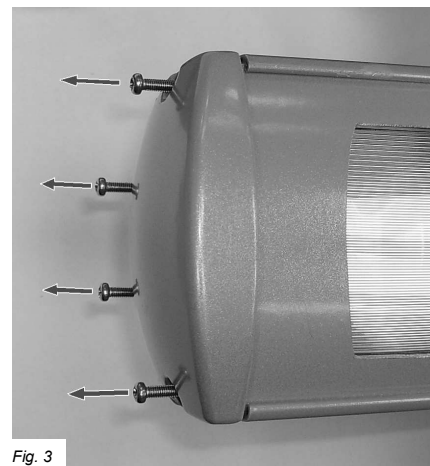

Fig. 3

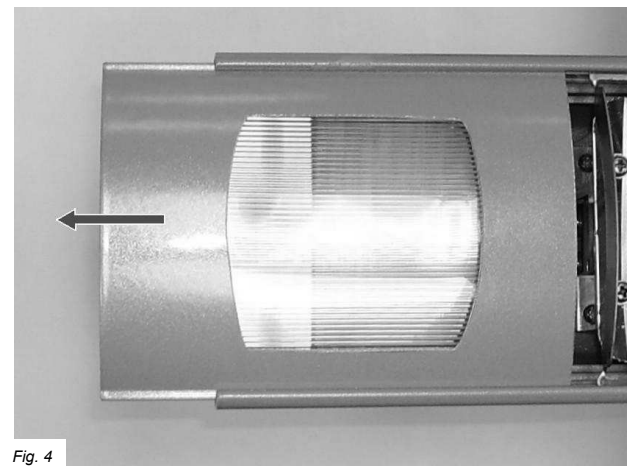

Fig. 4

6. Slide out the side covers from both ends and slide out the guard from either end (Fig. 3 & 4 shows side covers with lenses for models with lights).

7. Firstly remove the two screws as highlighted on the right of Fig. 5 to remove the side reflector. If your heater is a model with lights models you should then remove the two screws holding the bulb plate as highlighted on the left of Fig. 5 to allow the bulb plate to be lifted. Repeat at opposite end.

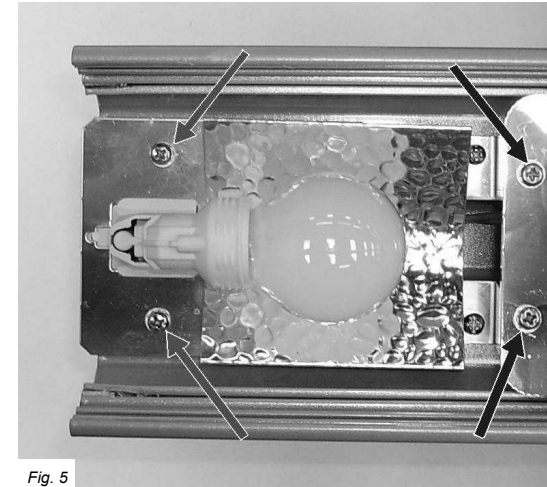

Fig. 5

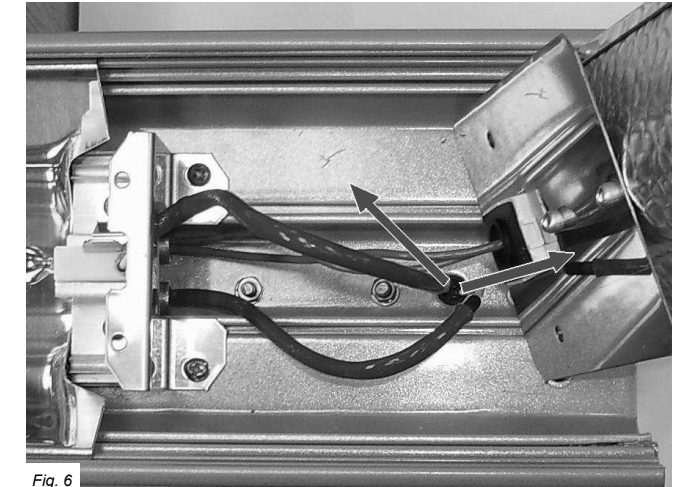

Fig. 6

8. Starting at the end where the emitter wires are fed through the gasket into the terminal box, if the heater has lights hold the bulb plate out of the way (Fig. 6) or if it is a heater only the wires will be clearly visible, gently pull the lamp wires through the body of the heater so the wires exit the terminal box (Fig 6).

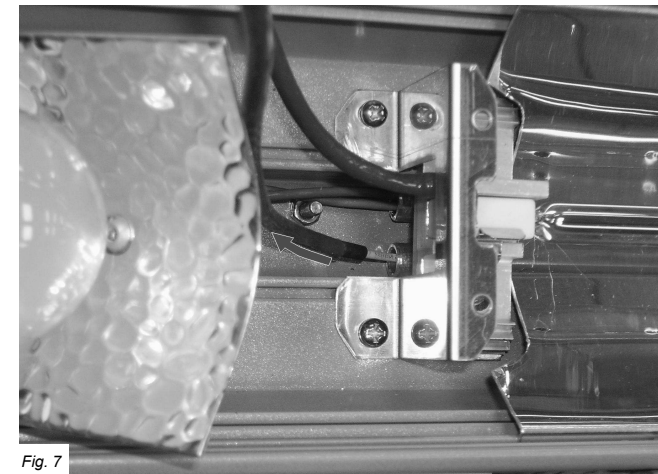

Fig. 7

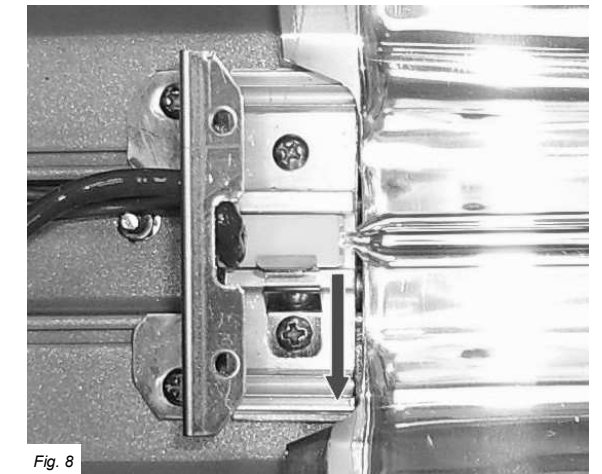

Fig. 8

9. At the opposite end of the heater, if the heater has lights hold the bulb plate out of the way (Fig. 7) or if it is a heater only the wire will be clearly visible in the feeder tube, gently pull the lamp wire out of the tube.
10. Pull the emitter wires through the side reflector bracket and then one at a time pull the spring clips back and lift up the ceramic caps of the emitter to remove it from the heater.
11. The emitter should now be removed from the heater. Refit the new emitter in reverse order ensuring the ceramic caps are correctly seated in the lamp holders, no wires are trapped and all screws are fully tightened.

Replacing the Light Bulbs (Heater with Lights Only)

If you are in any doubt about following the procedure below, please contact us for technical assistance. The mains power should be disconnected before any attempts are made to replace the lamp. The following should be carried out with compliance to latest IEE regulations. Please read the notes on the previous page with regards to handling and buying replacement bulbs before proceeding.

1. Ensure the heater, emitter and light bulbs are cool and the power supply is disconnected by removing the plugs from the socket outlet.
2. Providing there is reasonable access and you are standing on a safe and stable platform, the light bulbs can be replaced with the heater still mounted. Otherwise, remove the heater from its mounting and work on a safe, flat surface.

Continued...